

(continued from front)

16D galvanized nails. Do this with the three remaining corners. Square the structure by obtaining equal diagonal measurements from corner to corner, as shown in Figure 4. Using a level, now level the four walls up. This may take some adjusting and re-adjusting depending on the levelness of the ground.

#### Step 5: Installing The Trusses

*This step will be very difficult for one person to accomplish safely, so any assistance you can get would be very useful.*

Take the 2 x 6 ridge beam marked in Step 1. Make sure the left end is to the rear of the greenhouse so that the trusses will line up over the studs in walls A and B. Using the 1 1/4" hot dip galvanized joist hanger nails, nail a RR hanger to the ridge beam on both sides, rear and front. The top of the ridge beam should be 3/4" above the top of the RR hanger, to allow for the slope of the truss. You will need to bend the outer tabs of the RR hanger over so that they are flush with the front and back of the ridge beams.

Attach the remaining RR hangers along the length of the ridge beam so they are centered over the marks made in Step 1. Attach RR hangers to the top of the pony walls, so they are centered over the studs, with the open side facing into the greenhouse.

Set the long leg of the four corner trusses in the RR hangers on the ridge beam and nail in place using the 1 1/4" hot dip galvanized joist hanger nails. Stand this portion on top of the walls with the lower leg of the truss inside of the RR hanger. Nail the truss to the RR hanger. The truss system will not be stable at this point, but will stiffen as you proceed. Install the remaining trusses with nails into the RR hangers.

#### Step 6: Upper End Walls & Door Framing

Start with front wall D (See Figure 3 and 5). First cut out top plate (door opening) even with inside studs. This piece should be 38 1/2" long and will be used as a header for the door, so don't discard. Cut two 2 x 4's to 80" for door trimmers and nail in place. Take the door header, removed from top plate and nail on top of trimmers. The additional upper end wall framing inside the trusses from this point on, may vary depending on the exactness of the truss installation. Before cutting to measurements given, you should double-check the measurement. Cut horizontal 2 x 4 from truss to truss (approx. 101" - 104") and install. Cut and install upper wall studs and gable. (Again these measurements may vary slightly.) For wall C (rear) follow the same procedure - refer to Figure 6. The diagonal bracing should go from the top of the horizontal 2 x 4, and between the two gable studs, to the bottom of the ridge beam cut (approx. 27"). Install diagonal bracing. Using a level and square, adjust roof system until square.

#### Step 7: Installing The Door

Install door per instructions provided with the door. The door frame is attached to the door trimmers and header.

#### Step 8: Installing The T1-11 Siding At Door Opening

Measure the distance from the T1-11 panel on the left side of the door and cut the unused T1-11 panel to fill the opening. Install with 7D galvanized siding nails. Repeat this process with the open area to the right of the door.

#### Step 9: Installing The Palruf Corrugated Panels

*Be sure you wear safety glasses, dust mask and gloves when cutting corrugated Palruf!*

Have an assistant hold the Palruf panel across the face of the greenhouse so that it overlaps the T1-11 siding by about 2 inches. Match wiggle mold to the corrugations where they start at the upper edge of the panel next to the door trimmers. Mark and cut the wiggle mold to fit. Install wiggle mold on upper sides of door trimmers with 7D galvanized nails (The wiggle mold may split, unless nail holes are pre-drilled. Splitting will not have much effect on the performance and durability of the wiggle mold, but it will look best if not split.) Install three full sheets on the front and back faces of the greenhouse so that it overlaps the T1-11 siding by 2 inches. Overlap the Palruf panel by two bumps for the best seal. Use the galvanized nails with neoprene washers to attach the greenhouse panels to the walls and trusses. Cut the extending corrugated Palruf following outside edges of the trusses and around door opening.

Starting on one side, install wiggle mold on the lower leg of the end trusses (shown in detail inset Figure 6). Install the first full sheet of 2' x 12' Palruf so that it extends 2 inches over the T1-11 siding. Measure and cut each succeeding wiggle mold to match the corrugated Palruf as you install it. Overlap the Palruf panel by two bumps for the best seal. After you have installed the Palruf panel that wraps over the peak of the roof, remember to place the following panels so that they are underneath the previous panel at the overlap. This will allow water to drain over the top of the panels and not leak into the greenhouse. Use the remaining 2' x 12' pieces of Palruf to finish enclosing the roof. Trim the last piece of Palruf panel so that it overlaps the T1-11 by 2 inches.

Note: It is easier to install the Palruf on the face and back of the greenhouse before you install the roof. Also, it is easier to cut and match the wiggle mold to the panels if they are installed from one side, over the top and down the other side than it is to try to match the corrugations at the peak of the roof.

#### Step 10: Installing Trim

Cut and install cedar trim so that it holds down bottom edge of Palruf panel. 1 x 4 cedar trim will also go on four corners of lower walls and around doorframe.

**That's It! Enjoy Your New Greenhouse!**



## 12' x 12' Palruf Greenhouse Kit



Add value to your home and enjoy your Alaskan summers with an EZ Builder Greenhouse!

EZ Builder Kits have been designed with the Do-It-Yourselfer in mind.

[www.sbsalaska.com](http://www.sbsalaska.com)

Though no formal building experience is necessary to do this project, some areas may be confusing or difficult. If you have any questions, please feel free to call your local SBS store.



**spenard  
builders  
supply**



# 12' x 12' PALRUF GREENHOUSE KIT BUILDING STEPS

## Tools Required

- Stepladder (10' or taller)
- Hammer
- Nail Set
- Circular Saw/Hand Saw
- Screwdriver/Cordless Screwdriver
- Dust Mask
- Chalk Line
- Square
- Level
- Safety Glasses

## Material List

1 ea.	2 x 6	12' HF
12 ea.	2 x 4	12' HF
10 ea.	1 x 4	12' Cedar
6 ea.	5/8" x 4' x 8'	T1-11 Siding
29 ea.	2 x 4	45" Studs (precut)
7 pair		Greenhouse Trusses (prebuilt)
16 ea.	26" x 12'	Clear Palruf Greenhouse Panels
6 ea.	1 5/8" x 8'	Wiggle Mold
1 ea.		36" Econo Storm Door, Mill finish
5 lb.		Galvanized Nails with Neo-washers
3 lb.		7D Galvanized Siding Nails
5 lb.		16D Galvanized Boxed Nails
28 ea.	2 x 4	RR Hangers
2 lb.	1 1/4"	Hotdip Galvanized Joist Hanger Nails

Note: 12' x 12' is nominal size. Actual size is 143" x 142"

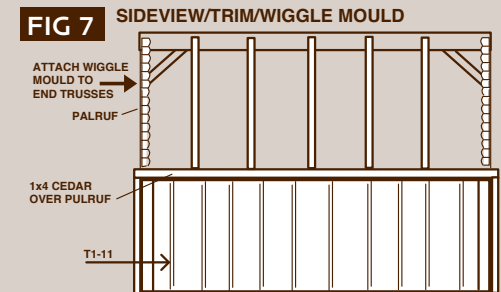
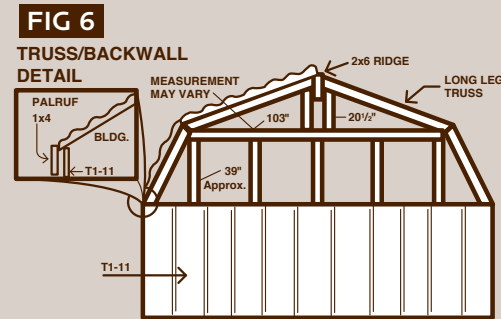
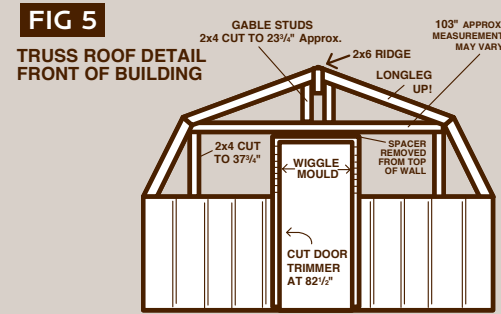
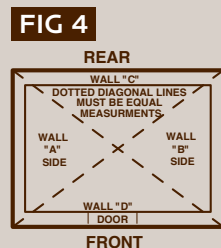
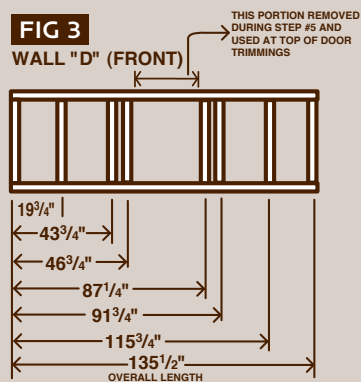
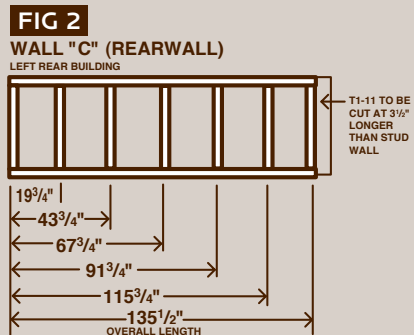
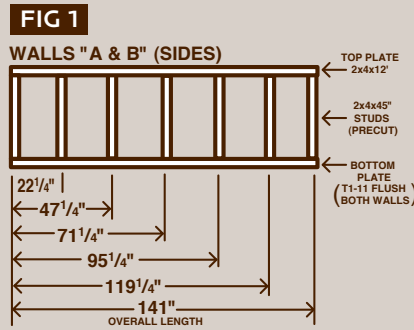

- The SBS greenhouse kit is not totally precut. Trusses and studs are precut. Some other cutting is required.
- It is possible for one person to build this kit, however it is much easier and we recommend that you have at least two people help with this construction.
- This kit does not have a floor. A floor kit is available as an option. If this greenhouse is to be set directly on the ground we recommend that treated 4 x 4's be placed below the bottom plate to protect against rot.
- Though no formal building experience is necessary to do this project, some areas may be confusing or difficult. If you have any questions, please feel free to call your local SBS store.

## Step 1: Laying Out The Walls

Walls A and B and the ridge beam will all be marked the same. Lay four 2 x 4 x 12' and one 2 x 6 x 12' side by side with ends flush and mark as shown in Figure 1. (Mark left to right, left will be considered the rear of the building). The overall length of the walls will be shorter than the 2 x 4 x 12' and 2 x 6 x 12', so you will need to trim excess 3" off each board. Mark walls C and D in the same manner, using Figures 2 and 3. Trim excess 8 1/2" off 2 x 4's.

## Step 2: Framing The Walls

The marks on the boards will be the center point for the wall studs and roof trusses.

Nail the A and B side walls together first, using the 45" studs and 16D nails (refer to Figure 1). The studs on the end of the walls should be flush with the edge of the wall top and bottom boards. Each inside stud must be centered over the marks on the top and bottom boards. Frame walls C and D in the same manner, refer to Figure 2 and 3.

Note: Be sure to mark walls in/out, top/bottom, rear/front to prevent confusion during construction.

## Step 3: Sheathing The Walls

Cut all T1-11 to 48" height. Use a chalk line to mark across the back of T1-11 before cutting. Nail T1-11 to walls A and B starting at rear (left) end. Keep T1-11 flush with all edges. Use 7D galvanized siding nails and nail into the grooves with nail set where possible. Trim excess T1-11 flush with front end of walls A and B.

Walls C and D require that you extend the T1-11 out 4 1/8" on both sides of the walls at each end. These extended ends will nail into the studs and overlap the T1-11 on the front and rear walls A and B. Again, be sure to start at left sides of walls C and D so end of T1-11 will fall onto studs. Use 7D galvanized siding nails and nail into the grooves with nail set where possible.

Nail the T1-11 to Wall C using three of the T1-11 panels. Measure and cut the third panel so that it overhangs the right edge of the wall by 4 1/8".

Nail the T1-11 to the outside ends of wall D so that it overhangs the left and right edges of the wall by 4 1/8". Do not nail the T1-11 to the center section. In Step 6 you will need to cut out the upper plate for the door opening and install the door trimmers. The T1-11 will be installed after this step.

## Step 4: Standing The Walls

Stand the walls as shown in Figure 4. Be sure the stud patterns for walls A and B match from side to side. Pull corners tight. Nail T1-11 and wall studs together using

(continued on back)